



US009306188B2

(12) **United States Patent**
Kim et al.

(10) **Patent No.:** **US 9,306,188 B2**
(45) **Date of Patent:** **Apr. 5, 2016**

(54) **ORGANIC LIGHT EMITTING DIODE DISPLAY**

- (71) Applicant: **SAMSUNG DISPLAY CO., LTD.**,
Yongin, Gyeonggi-Do (KR)
- (72) Inventors: **Min Seop Kim**, Cheonan-si (KR); **Hwan Jin Kim**, Hwaseong-si (KR)
- (73) Assignee: **Samsung Display Co., Ltd.**, Yongin-si (KR)
- (*) Notice: Subject to any disclaimer, the term of this patent is extended or adjusted under 35 U.S.C. 154(b) by 0 days.

(21) Appl. No.: **14/290,966**

(22) Filed: **May 29, 2014**

(65) **Prior Publication Data**
US 2015/0108439 A1 Apr. 23, 2015

(30) **Foreign Application Priority Data**
Oct. 17, 2013 (KR) 10-2013-0124226

(51) **Int. Cl.**
H01L 51/52 (2006.01)
H01L 27/32 (2006.01)
H01L 51/00 (2006.01)

(52) **U.S. Cl.**
 CPC **H01L 51/5256** (2013.01); **H01L 27/323** (2013.01); **H01L 27/3272** (2013.01); **H01L 51/524** (2013.01); **H01L 51/5237** (2013.01); **H01L 51/0097** (2013.01); **H01L 2251/5338** (2013.01)

(58) **Field of Classification Search**
CPC H01L 2251/5338; H01L 51/0096; H01L 51/0097; H01L 51/52; H01L 51/5237
USPC 257/100, 40, 414, 428, 437; 438/26, 99
See application file for complete search history.

(56) **References Cited**

U.S. PATENT DOCUMENTS

- 7,348,964 B1 * 3/2008 Gettemy G06F 1/1626
178/18.01
- 7,781,850 B2 * 8/2010 Miles B81B 3/0086
257/414
- 7,826,006 B2 * 11/2010 Koganezawa G02F 1/133611
349/56
- 7,920,223 B2 * 4/2011 Nishizawa G02F 1/133308
349/58
- 8,348,467 B2 * 1/2013 Khan F21K 9/52
362/254
- 8,853,941 B2 * 10/2014 Jung G06F 1/1637
313/504
- 2002/0027636 A1 * 3/2002 Yamada G02F 1/133305
349/155

(Continued)

FOREIGN PATENT DOCUMENTS

- KR 10-0965251 B1 6/2010
- KR 10-2012-0079672 A 7/2012

Primary Examiner — Stephen W Smoot

Assistant Examiner — Edward Chin

(74) *Attorney, Agent, or Firm* — Lewis Roca Rothgerber Christie LLP

(57) **ABSTRACT**

An organic light emitting diode display having a flat region having a flat surface, and curved regions disposed at left and right sides of the flat region and formed in curved surfaces, having a display panel including a substrate, which maintains a flat surface in the flat region, and is formed in curved surfaces in the curved regions, and organic light emitting diodes disposed on the substrate, a window disposed in the flat region and the curved regions on the display panel, and a cover member disposed under the display panel, in which the cover member includes a flat cover member disposed in the flat region and curved cover members disposed in the curved regions, and the flat cover member and the curved cover member are formed of different materials or have different thicknesses.

12 Claims, 4 Drawing Sheets

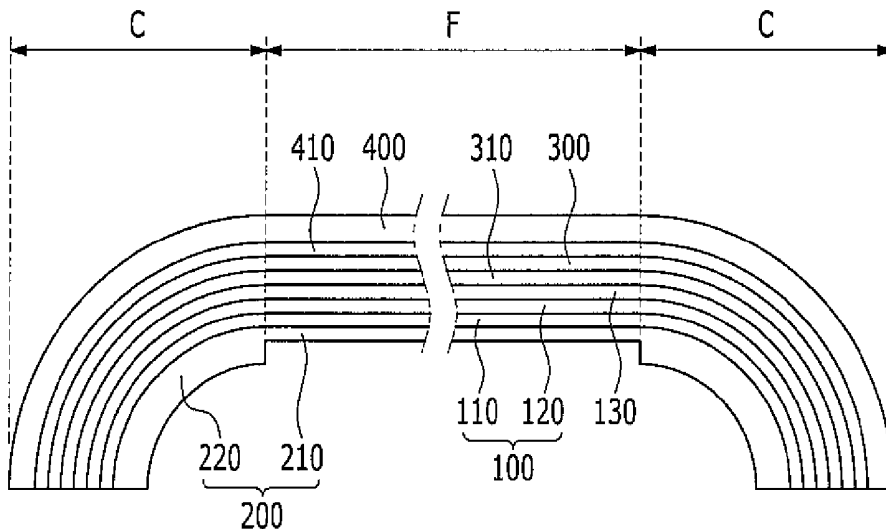

(56)

References Cited

U.S. PATENT DOCUMENTS

2002/0105789	A1 *	8/2002	Chen	H01L 23/3128 361/767	2009/0279241	A1 *	11/2009	Gettemy	G06F 1/1601 361/679.26
2002/0180712	A1 *	12/2002	Sato	G06F 13/04 345/173	2013/0002133	A1 *	1/2013	Jin	G06F 1/169 313/511
2006/0273304	A1 *	12/2006	Cok	H01L 51/0096 257/40	2013/0020747	A1	1/2013	Kumagai		
2007/0146569	A1 *	6/2007	Nouchi	G02B 6/0088 349/58	2014/0002973	A1 *	1/2014	Lee	H05K 7/00 361/679.01
						2014/0002975	A1 *	1/2014	Lee	H05K 5/0017 361/679.01
						2014/0345791	A1 *	11/2014	Son	B32B 37/0046 156/228

* cited by examiner

FIG. 1

1000

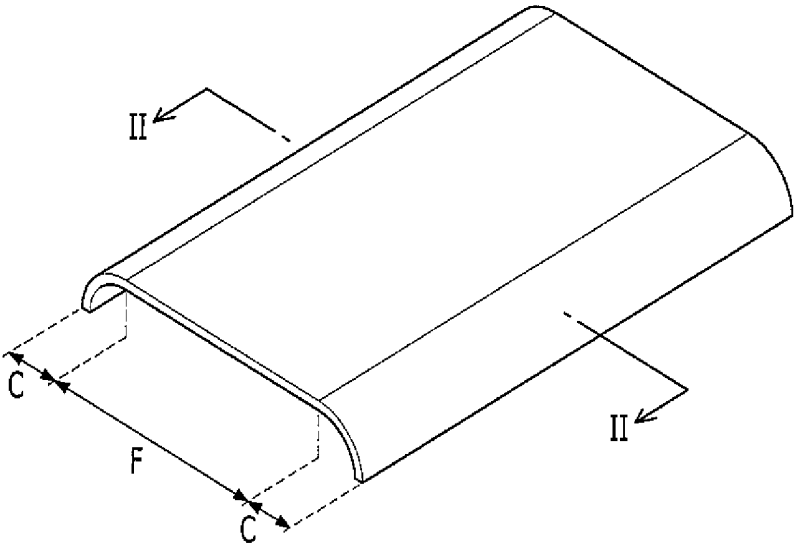

FIG. 2

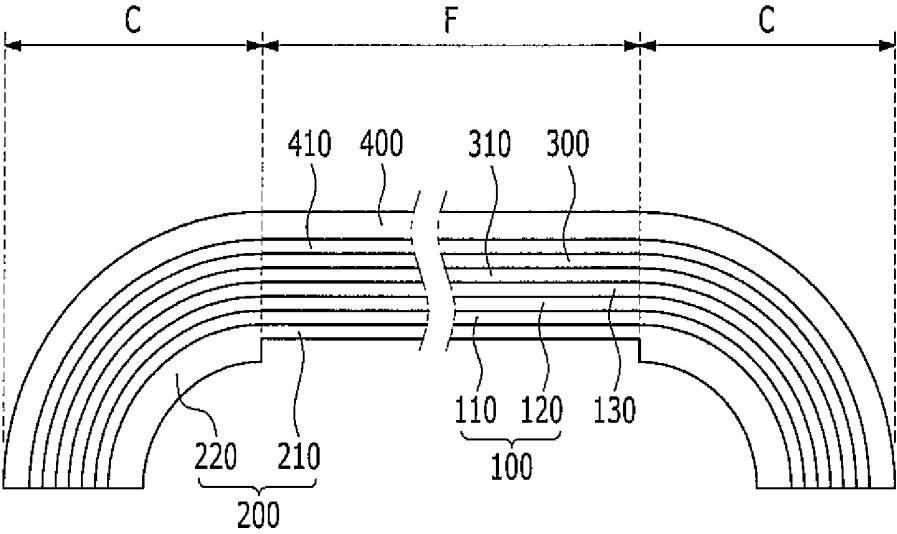

FIG. 3

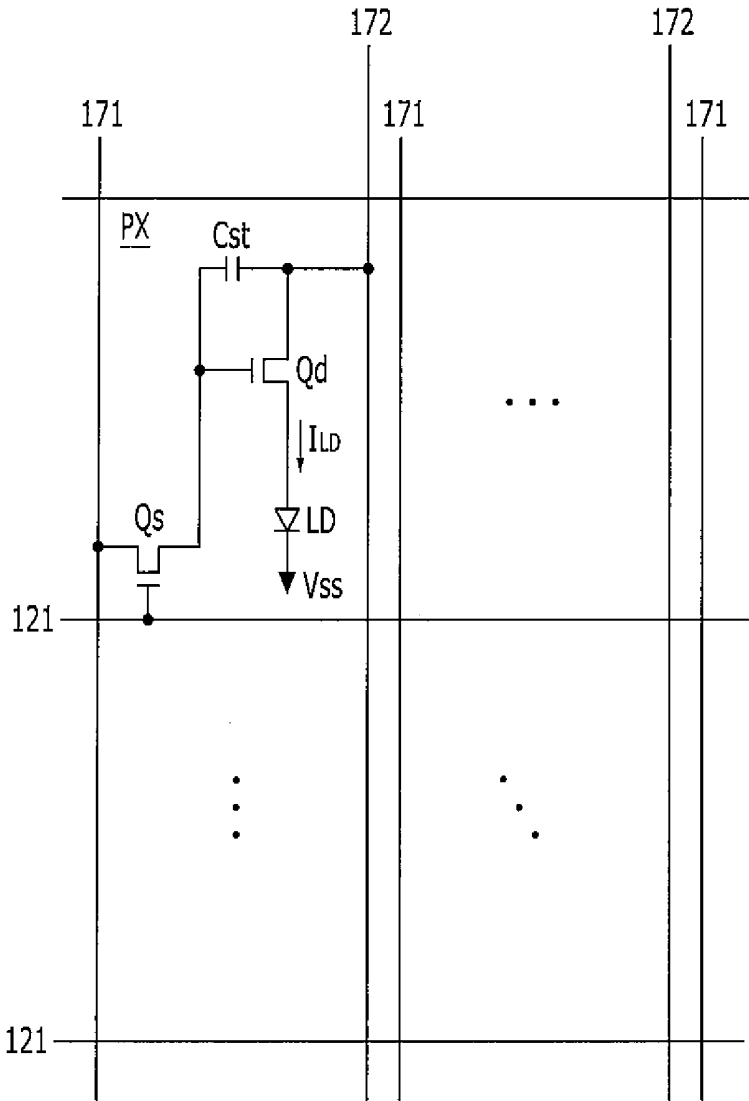
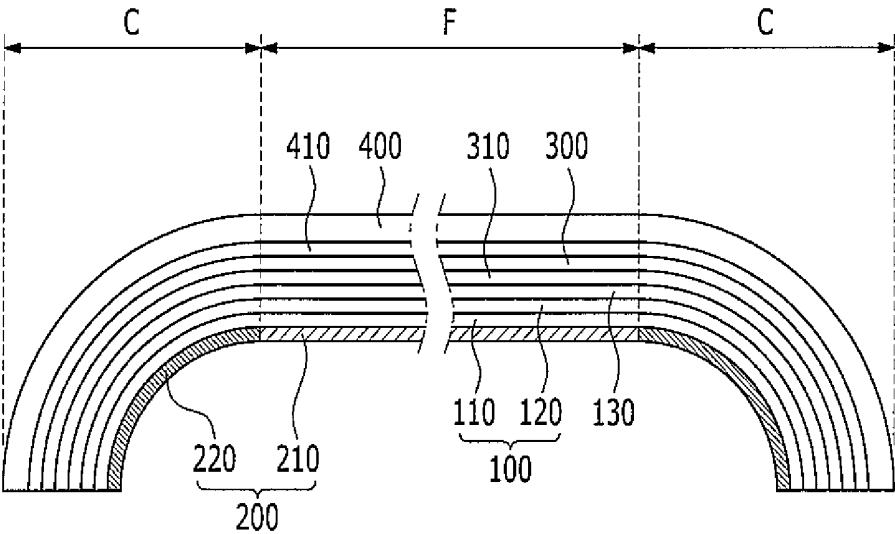

FIG. 4



ORGANIC LIGHT EMITTING DIODE DISPLAY

CROSS-REFERENCE TO RELATED APPLICATION

This application claims priority to and the benefit of Korean Patent Application No. 10-2013-0124226 filed in the Korean Intellectual Property Office on Oct. 17, 2013, the entire contents of which are incorporated herein by reference.

BACKGROUND

1. Field

The present invention relates to an organic light emitting diode display.

2. Description of the Related Art

Recently, lightness and flatness of a monitor, a television, and the like have been demanded, and a cathode ray tube (CRT) has been substituted with a liquid crystal display (LCD) according to the demand. However, the liquid crystal display, which is a light receiving element, requires a separate backlight, and has limitations in response speed, viewing angle, and the like.

As a display device capable of overcoming the aforementioned limitations, an organic light emitting device, which is a self-emitting display element, has advantages of a wide viewing angle, excellent contrast, and a fast response time and therefore has greatly attracted attention.

In the meantime, a flexible organic light emitting diode display has a flat portion and a curved portion. The curved portion is formed in a curved surface having a curvature, so that tolerance may be generated in the curved portion compared to the flat portion when a product is assembled.

The above information disclosed in this Background section is only for enhancement of an understanding of the background of the invention and therefore it may contain information that does not form the prior art that is already known to a person of ordinary skill in the art.

SUMMARY

Embodiments of the present invention has been made in an effort to provide an organic light emitting diode display having the ability of absorbing tolerance of a curved portion when an organic light emitting diode display including the curved portion is assembled. An exemplary embodiment of the present invention provides an organic light emitting diode display having a flat region maintaining a flat surface, and curved regions disposed at left and right sides of the flat region and formed in curved surfaces, including: a display panel including a substrate, which maintains a flat surface in the flat region, and is formed in curved surfaces in the curved regions, and organic light emitting diodes disposed on the substrate; a window disposed in the flat region and the curved regions on the display panel; and a cover member disposed under the display panel, in which the cover member includes a flat cover member disposed in the flat region and curved cover members disposed in the curved regions, and the flat cover member and the curved cover member are formed of different materials or have different thicknesses.

The cover member may be formed of a cushion or a sponge.

The flat cover member and the curved cover member may have different thicknesses.

The thickness of the curved cover member may be larger than the thickness of the flat cover member by about 1.5 times to about 3 times.

The flat cover member and the curved cover member may be formed of the same material.

The flat cover member and the curved cover member may be formed of different materials.

A density of the flat cover member may be larger than a density of the curved cover member by about 3 times to about 10 times.

The flat cover member and the curved cover member may have the same thickness.

The organic light emitting diode display according to an exemplary embodiment of the present invention may further include a touch panel disposed between the display panel and the window.

The touch panel may be disposed in the flat region and the curved regions.

The curved regions may be disposed to be extended from the flat region.

The flat region and the curved regions may display an image.

According to exemplary embodiments of the present invention, the cover member disposed under the display panel may include the flat cover member and the curved cover members formed of different materials or having different thicknesses, thereby absorbing tolerance in a curved portion when the organic light emitting diode display including the curved portion is assembled.

BRIEF DESCRIPTION OF THE DRAWINGS

FIG. 1 is a perspective view schematically illustrating an organic light emitting diode display according to an exemplary embodiment of the present invention.

FIG. 2 is a cross-sectional view taken along line II-II of FIG. 1.

FIG. 3 is an equivalent circuit diagram of the organic light emitting diode display of FIG. 1.

FIG. 4 is a cross-sectional view illustrating a cross-section of an organic light emitting diode display according to another exemplary embodiment of the present invention.

DETAILED DESCRIPTION

Exemplary embodiments of the present invention will be described in detail with reference to the accompanying drawings. As those skilled in the art would realize, the described embodiments may be modified in various different ways, all without departing from the spirit or scope of the present invention. On the contrary, exemplary embodiments introduced herein are provided to make disclosed contents thorough and complete and sufficiently transfer the spirit of the present invention to those skilled in the art.

In the drawings, the thickness of layers and regions are exaggerated for clarity. It will be understood that when a layer is referred to as being "on" another layer or substrate, it can be directly on the other layer or substrate, or intervening layers may also be present. Like reference numerals designate like components throughout the specification.

FIG. 1 is a perspective view schematically illustrating an organic light emitting diode display according to an exemplary embodiment of the present invention.

Referring to FIG. 1, an organic light emitting diode display 1000 according to an exemplary embodiment of the present invention includes a flat region F and curved regions C disposed at left and right sides of the flat region F. The flat region F and the curved regions C display an image.

The flat region F substantially maintains a flat surface, and may serve as a main display screen of the organic light emitting diode display **1000**.

The curved regions C are disposed to be extended from the flat region F, and are formed in a curved surface having a predetermined radius curvature. The curved regions C may serve as sub display screens of the organic light emitting diode display **1000**.

As described above, the organic light emitting diode display **1000** according to the present exemplary embodiment includes the flat region F maintaining a flat surface, and the curved regions C extended from the flat region F and formed in a curved surface having the predetermined radius curvature, so that the display screen of the organic light emitting diode display **1000** is not limited to the flat region F, and is extended to the curved regions C to be viewed by a user. That is, an entire display screen of the organic light emitting diode display **1000** may be increased by the curved regions C.

Further, in instances where the organic light emitting diode display **1000** according to the present exemplary embodiment is a portable type, a feeling of holding, that is, a grip feeling, of the organic light emitting diode display **1000** may be improved by the curved regions C.

Next, a structure of the organic light emitting diode display according to the exemplary embodiment of the present invention will be described with reference to FIGS. **2** and **3**.

FIG. **2** is a cross-sectional view taken along line II-II of FIG. **1**, and FIG. **3** is an equivalent circuit diagram of the organic light emitting diode display of FIG. **1**.

Referring to FIG. **2**, the organic light emitting diode display **1000** includes a display panel **100**, a polarization plate **130**, a touch panel **300**, and a window **400** sequentially disposed on the display panel **100**.

Further, the organic light emitting diode display **1000** according to the present exemplary embodiment includes a cover member **200** attached under the display panel **100**.

The display panel **100** includes a substrate **110** and a thin film layer **120** disposed on the substrate **110**.

The substrate **110** is a flexible substrate, and may be formed of a plastic material having heat resistance and durability, such as polyethylene naphthalate (PEN), polycarbonate (PC), polyarylate (PAR), polyether imide (PEI), polyether sulfone (PES), and polyimide (PI). Further, the substrate **110** is not limited thereto, and may be formed of various materials having flexibility.

The substrate **110** maintains a flat surface in the flat region F, and is formed in a curved surface in the curved region C. Because the substrate **110** is a flexible substrate, the substrate **110** may be formed in a curved surface in the curved region C.

The thin film layer **120** includes a plurality of organic light emitting diodes emitting light. Further, the thin film layer **120** includes a plurality of thin film transistors connected to the organic light emitting diodes, and a plurality of gate lines and a plurality of data lines connected to the thin film transistors. Further, the thin film layer **120** may further include color filters displaying red, blue, and green.

Here, the organic light emitting diodes are disposed in the flat region F and the curved regions C, so that an image is displayed in the flat region F and the curved regions C.

Next, the organic light emitting diode display according to the exemplary embodiment of the present invention will be described in detail through an equivalent circuit diagram of the organic light emitting diode display including the organic light emitting diodes.

Referring to FIG. **3**, the organic light emitting diode display according to an exemplary embodiment includes a plurality of signal lines **121**, **171**, and **172**, and a plurality of

pixels connected to the plurality of signal lines **121**, **171**, and **172** and approximately arranged in a matrix form.

The signal line includes a plurality of gate lines **121** transferring a gate signal (or a scan signal), a plurality of data lines **171** transferring a data signal, and a plurality of driving voltage lines **172** transferring a driving voltage. The gate lines **121** extend substantially in a row direction and are almost parallel to each other, and the data lines **171** and the driving voltage lines **172** extend substantially in a column direction and are almost parallel to each other.

Each pixel PX includes a switching transistor Qs, a driving transistor Qd, a storage capacitor Cst, and an organic light emitting diode LD.

The switching transistor Qs has a control terminal, an input terminal, and an output terminal, and the control terminal is connected to the gate line **121**, the input terminal is connected to the data line **171**, and the output terminal is connected to the driving transistor Qd. The switching transistor Qs transfers a data signal applied to the data line **171** to the driving transistor Qd in response to a scan signal applied to the gate line **121**.

The driving transistor Qd also has a control terminal, an input terminal, and an output terminal, and the control terminal is connected to the switching transistor Qs, the input terminal is connected to the driving voltage line **172**, and the output terminal is connected to the organic light emitting diode LD. The driving transistor Qd outputs an output current I_{LD} having a size change according to a voltage between the control terminal and the output terminal.

The capacitor Cst is connected between the control terminal and the input terminal of the driving transistor Qd. The capacitor Cst charges a data signal applied to the control terminal of the driving transistor Qd, and maintains the charged data signal even after the switching transistor is turned off.

The organic light emitting diode LD has an anode connected to the output terminal of the driving transistor Qd and a cathode connected to a common voltage Vss. The organic light emitting diode LD emits light by changing intensity of light according to the output current I_{LD} of the driving transistor Qd, thereby displaying an image.

The switching transistor Qs and the driving transistor Qd are an n-channel field effect transistor (FET). However, at least one of the switching transistor Qs and the driving transistor Qd may be a p-channel field effect transistor. Further, a connection relationship between the transistors Qs and Qd, the capacitor Cst, and the organic light emitting diode LD may be changed.

Referring back to FIG. **2**, the polarization plate **130** is disposed on the display panel **100**, and the touch panel **300** is disposed on the polarization plate **130**.

A user writes or draws characters or pictures or executes an icon by contacting a finger or a touch pen (stylus) onto the touch panel **300**, so that the touch panel **300** allows a desired command to be performed.

The polarization plate **130** and the touch panel **300** have flexibility, and are disposed in the flat region F and the curved regions C. The touch panel **300** is attached to the polarization plate **130** through a touch panel adhesive layer **310**. Further, the touch panel **300** may be omitted.

The window **400** for protecting the touch panel **300** and the display panel **100** from impact from the outside and inflow of foreign substances and supporting the touch panel **300** and the display panel **100** is disposed on the touch panel **300**. The window **400** is attached to the touch panel **300** through a window adhesive layer **410**. The window **400** is transparent, and has transmittance at a level at which an image displayed on the display panel **100** is transmittable well.

The window **400** is disposed in the flat region F and the curved regions C. That is, the window **400** maintains a curved shape in the curved region C. Accordingly, the window **400** serves as a supporting means for supporting so that the display panel **100** and the touch panel **300** maintain the curved shape in the curved region C.

A cover member **200** is disposed under the display panel **100**. The cover member **200** may be attached to the display panel **100** through an adhesive.

The cover member **200** buffers external impact when the external impact is applied to the display panel **100**, so as to protect the display panel **100**, and is made of a material, which may contain air to absorb impact, such as a cushion or a sponge.

The cover member **200** includes a flat cover member **210** and curved cover members **220** formed of different materials or having different thicknesses.

In the present exemplary embodiment, the thicknesses of the flat cover member **210** and the curved cover member **220** are different from each other, and the materials of the flat cover member **210** and the curved cover member **220** are the same as each other. The flat cover member **210** is disposed in the flat region F, and the curved cover member **220** is disposed in the curved region C.

Here, the thickness of the curved cover member **220** is larger than the thickness of the flat cover member **210** by about 1.5 times to about 3 times.

In the curved region C, the display panel **100**, the polarization plate **130**, the touch panel **300**, and the window **400** are formed with a curved surface having a curvature, so that tolerance may be generated when the organic light emitting diode display is assembled, and the curved cover member **220** is formed to be thicker than the thickness of the flat cover member **210** by about 1.5 times to about 3 times, thereby absorbing the tolerance when the organic light emitting diode display is assembled.

Further, the flat cover member **210** is formed to be thinner than the curved cover member **220**, thereby preventing a thickness of the organic light emitting diode display **1000** from being thicker in the flat region F.

A case (not shown) for accommodating and supporting the display panel **100** may also be disposed under the cover member **200**.

As described above, the cover member **200** including the flat cover member **210** and the curved cover members **220** having different thicknesses is attached under the display panel **100**, thereby achieving an effect of protecting the display panel **100** from external impact and absorbing tolerance when the organic light emitting diode display is assembled.

Next, an organic light emitting diode display according to another exemplary embodiment of the present invention will be described with reference to FIG. 4.

FIG. 4 is a cross-sectional view illustrating a cross-section of an organic light emitting diode display according to another exemplary embodiment of the present invention.

Referring to FIG. 4, in comparison with the organic light emitting diode display illustrated in FIG. 2, the organic light emitting diode display according to the present exemplary embodiment is different from the organic light emitting diode display illustrated in FIG. 2 with respect to a shape of cover member **200**, but has the same remaining structures as those of the organic light emitting diode display illustrated in FIG. 2. Accordingly, descriptions of the same structures will be omitted.

Cover member **200** is disposed under a display panel **100**. The cover member **200** may be attached to the display panel **100** through an adhesive.

The cover member **200** buffers external impact when the external impact is applied to the display panel **100** to protect the display panel **100**, and is made of a material, which contains air to absorb impact, such as a cushion or a sponge.

The cover member **200** includes a flat cover member **210** and curved cover members **220** formed of different materials or having different thicknesses.

In the present exemplary embodiment, the materials of the flat cover member **210** and the curved cover member **220** are different from each other, and the thicknesses of the flat cover member **210** and the curved cover member **220** are the same as each other. The flat cover member **210** is disposed in a flat region F, and the curved cover member **220** is disposed in a curved region C.

Here, density of the flat cover member **210** is larger than a density of the curved cover member **220** by about 3 times to about 10 times.

The density of the curved cover member **220** is smaller than the density of the flat cover member **210**, so that the curved cover member **220** may be free to be formed in a curved surface in the curved region C.

In the curved region C, the display panel **100**, a polarization plate **130**, a touch panel **300**, and a window **400** are formed in the curved surface having a curvature, so that tolerance may be generated when the organic light emitting diode display is assembled, and the density of the curved cover member **220** is smaller than the density of the flat cover member **210**, so that it is possible to absorb the tolerance when the organic light emitting diode display is assembled.

A case (not shown) for accommodating and supporting the display panel **100** may also be disposed under the cover member **200**.

While this invention has been described in connection with exemplary embodiments thereof, it is to be understood that the invention is not limited to the disclosed embodiments, but, on the contrary, is intended to cover various modifications and equivalent arrangements included within the spirit and scope of the appended claims.

Description of symbols

100: Display panel	110: Substrate
120: Thin film layer	200: Cover member
210: Flat cover member	220: Curved cover member
300: Touch panel	400: Window

What is claimed is:

1. An organic light emitting diode display having a flat region having a flat surface, and curved regions disposed at left and right sides of the flat region and formed in curved surfaces, comprising:

a display panel including a substrate having a flat surface in the flat region, and curved surfaces in the curved regions, and organic light emitting diodes disposed on the substrate;

a window disposed on a top side of the display panel, the window comprising a flat window surface on the flat surface of the display panel and curved window surfaces on the curved surfaces of the display panel; and

a cover member disposed on a bottom side of the display panel such that the display panel is disposed between the window and the cover member,

wherein the cover member includes a flat cover member disposed in the flat region and curved cover members disposed in the curved regions, and

7

wherein the flat cover member is formed from a first material having a first density and at least one of the curved cover members is formed from a second material having a second density less than the first density.

2. The organic light emitting diode display of claim 1, wherein at least one selected from the flat cover member and the curved cover members is formed of a cushion or a sponge.

3. The organic light emitting diode display of claim 1, wherein the flat cover member and the curved cover member are formed of different materials.

4. The organic light emitting diode display of claim 2, wherein the first density of the flat cover member is larger than the second density of the at least one of the curved cover members by about 3 times to about 10 times.

5. The organic light emitting diode display of claim 4, wherein the flat cover member and the curved cover members have the same thickness.

6. The organic light emitting diode display of claim 1, further comprising a touch panel disposed between the display panel and the window.

7. The organic light emitting diode display of claim 6, wherein the touch panel is disposed in the flat region and the curved regions.

8. The organic light emitting diode display of claim 1, wherein the curved regions extend from the flat region.

9. The organic light emitting diode display of claim 8, wherein the flat region and the curved regions are configured to display an image.

10. An organic light emitting diode display having a flat region having a flat surface, and curved regions disposed at left and right sides of the flat region and formed in curved surfaces, comprising:

8

a display panel including a substrate having a flat surface in the flat region, and curved surfaces in the curved regions, and organic light emitting diodes disposed on the substrate;

a window disposed on a top side of the display panel, the window comprising a flat window surface on the flat surface of the display panel and curved window surfaces on the curved surfaces of the display panel; and

a cover member disposed on a bottom side of the display panel such that the display panel is disposed between the window and the cover member,

wherein the cover member includes a flat cover member disposed in the flat region and curved cover members disposed in the curved regions, and

wherein the flat cover member has a first thickness measured along a direction normal to the flat cover member and each of the curved cover members has a second thickness larger than the first thickness measured along a direction normal to respective ones of the curved cover members.

11. The organic light emitting diode display of claim 10, wherein the second thickness of each of the curved cover members is larger than the first thickness of the flat cover member by about 1.5 times to about 3 times.

12. The organic light emitting diode display of claim 11, wherein the flat cover member and the curved cover member are formed of the same material.

* * * * *

专利名称(译)	有机发光二极管显示器		
公开(公告)号	US9306188	公开(公告)日	2016-04-05
申请号	US14/290966	申请日	2014-05-29
[标]申请(专利权)人(译)	三星显示有限公司		
申请(专利权)人(译)	三星DISPLAY CO. , LTD.		
当前申请(专利权)人(译)	三星DISPLAY CO. , LTD.		
[标]发明人	KIM MIN SEOP KIM HWAN JIN		
发明人	KIM, MIN SEOP KIM, HWAN JIN		
IPC分类号	H01L51/52 H01L27/32 H01L51/00		
CPC分类号	H01L51/5256 H01L27/323 H01L27/3272 H01L51/524 H01L51/5237 H01L51/0097 H01L2251/5338 G09F9/30 H01L51/5246 H01L2251/558		
助理审查员(译)	下巴, EDWARD		
优先权	1020130124226 2013-10-17 KR		
其他公开文献	US20150108439A1		
外部链接	Espacenet USPTO		

摘要(译)

一种有机发光二极管显示器，具有平坦表面的平坦区域，以及设置在平坦区域的左侧和右侧并形成成为曲面的弯曲区域，具有包括基板的显示面板，该基板在平坦区域中保持平坦表面区域，并且形成在弯曲区域中的弯曲表面中，并且设置在基板上的有机发光二极管，设置在平坦区域中的窗口和显示面板上的弯曲区域，以及设置在显示面板下方的盖构件，盖构件包括设置在平坦区域中的平坦盖构件和设置在弯曲区域中的弯曲盖构件，并且平盖构件和弯曲盖构件由不同材料形成或具有不同厚度。

An organic light emitting diode display having a flat region having a flat surface, and curved regions disposed at left and right sides of the flat region and formed in curved surfaces, having a display panel including a substrate, which maintains a flat surface in the flat region, and is formed in curved surfaces in the curved regions, and organic light emitting